

NOTES:

- 1) ALL WIRE CONNECTIONS TO STEEL PIPE TO BE CADWELDED AND COATED WITH PRIMER, PROTECTO-WRAP AND TAPE. USE CALDWELD STOCK #47-0038. AND CALDWELD SLEEVE STOCK #47-0037.
- 2) STEEL VALVE BOX LID TO BE MARKED BY WELDING "TS" FOR TEST STATION. TEST LEAD WIRE TO BE LONG ENOUGH TO EXTEND ONE FOOT ABOVE GROUND LEVEL AND SHALL TERMINATE IN VALVE BOX.
- 3) USE 3/4" PVC OR PE AS A LEAD WIRE CONDUCTOR PIPE PLACED APPROXIMATELY 6" ABOVE CARRIER PIPE AND INTO TEST STATION BOX.
- 4) ANODE CAN BE INSTALLED VERTICALLY OR HORIZONTALLY BUT MUST HAVE A A MINIMAL RADIAL CLEARANCE OF TWO FEET FROM THE STEEL PIPE AND BE POSITIONED AT AN ELEVATION NO HIGHER THAN THE STEEL PIPE.
- 5) LEAD WIRES MUST BE CONNECTED. USE SILICONE WIRE CONNECTOR STOCK #57-1138.

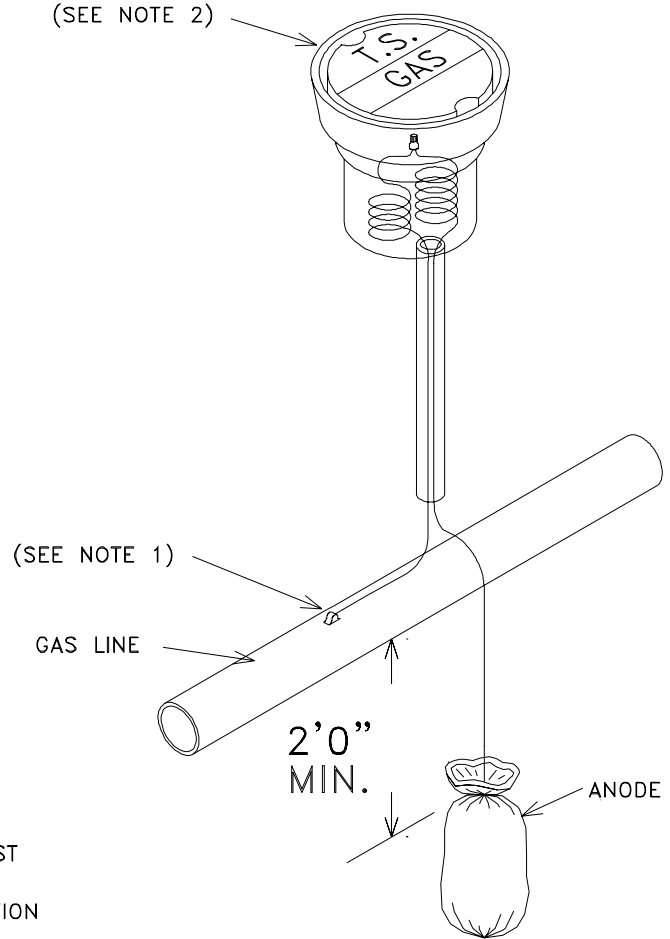

MATERIAL LIST

STOCK #	QTY.	DESCRIPTION
47-0035	1.0	ANODE MAGNESIUM 32 LB. WITH COVERING
45-7600	5.0	WIRE, TRACER, YELLOW WITH BLACK STRIPE #14
43-0010	1.0	BOX 6" VALVE CAST IRON
43-0095	1.0	COVER BOX VALVE GAS 6" (NEW STYLE)
47-0180	1.0	PRIMER
47-0260	0.2	TAPE PROTECTO-WRAP 6 IN. X 50 FT.
47-0290	0.2	TAPE BLACK 1 IN. X 100 FT.