

MATERIAL LIST

STOCK #	QTY.	DESCRIPTION
45-0190	1.0	CAP PIPE 8-5/8" O.D. WELDING
45-2198	1.0	TEE SERVICE 3/4" WELD X 3/4" THREAD FOR PURGING
45-0140	1.0	CAP 3/4" FIPT BLACK IRON

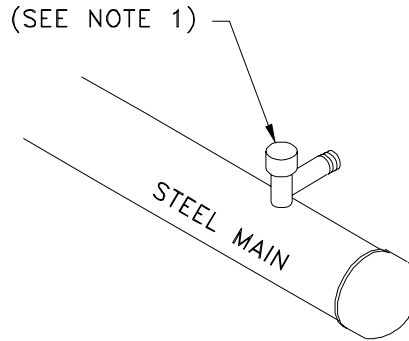

NOTES:

- 1) PURGE TEE TO BE WELDED ONE FOOT FROM END OF MAIN.
- 2) PURGE STACK MUST BE USED TO PURGE ABOVE WORKER'S HEAD. STACK AND RISER MUST BE PROPERLY GROUNDED. DO NOT PURGE INTO BELL HOLE.
- 3) AFTER PURGING IS COMPLETE, RETIRE WITH 3/4" CAP FIPT BLACK IRON. SOAP TEST UNDER OPERATING PRESSURE, THEN LEAVE THE SERVICE TEE IN THE CLOSED POSITION.
- 4) COAT ALL EXPOSED STEEL PIPE AND CAP WITH PRIMER, PROTECTO-WRAP AND TAPE. COAT SERVICE TEE WITH PRIMER AND TAPE.