

NOTES:

- 1) ALL WIRE SPLICES TO BE MADE USING A SPLIT BOLT CONNECTOR WRAPPED WITH AQUA-SEAL AND ELECTRICAL TAPE.
- 2) TRACER WIRE FOR PE GAS MAINS TO BE AWG #14 COPPERCLAD STAINLESS STEEL WITH SOLID YELLOW INSULATION.
- 3) TRACER WIRE, STOCK ITEM #45-7500, TO BE INSTALLED PER THE CONSTRUCTION SPECIFICATIONS.

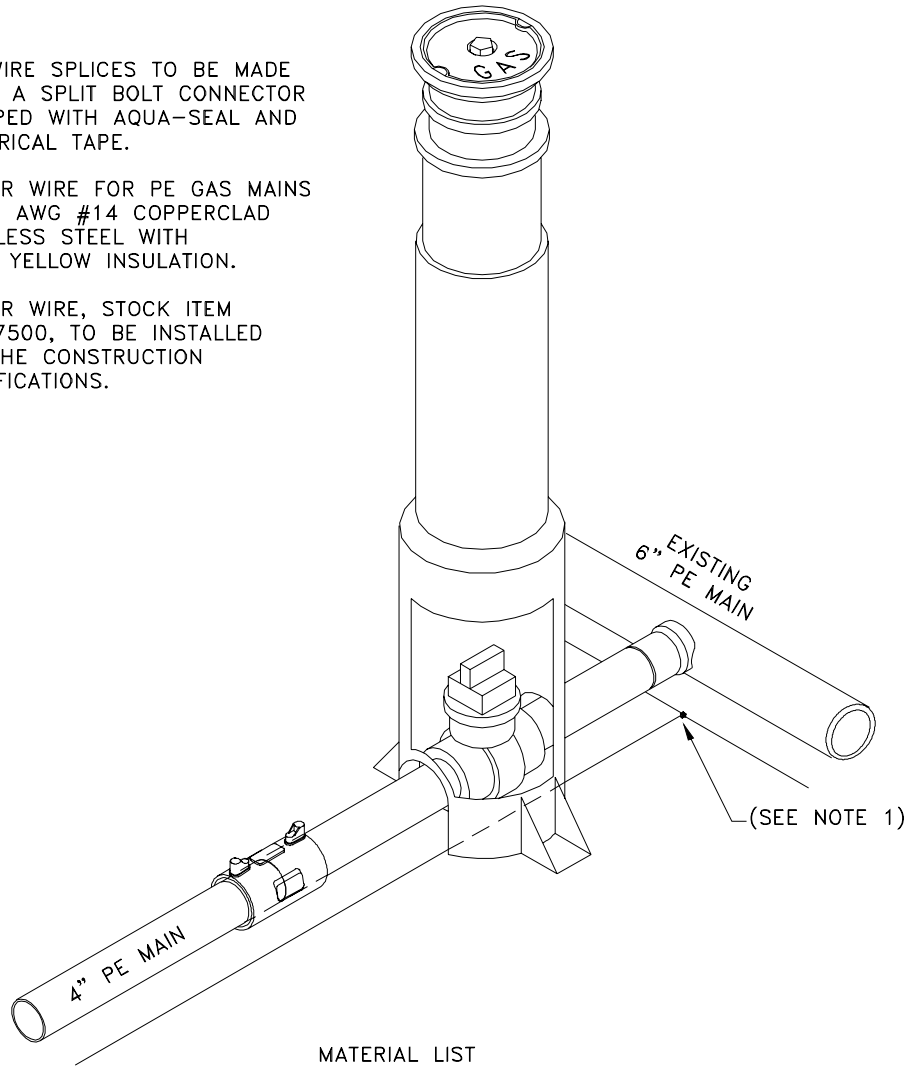

MATERIAL LIST

STOCK #	QTY.	DESCRIPTION
43-2040	1.0	VALVE 4" PE3408
45-5016	1.0	SADDLE BRANCH PLEXCO 6" X 4" PE3408 BUTT FUSION
45-0644	1.0	COUPLING ELECTROFUSION 4" IPS
43-0020	1.0	BOX 3" & 4" PE VALVES TRAFFIC RATED H-20
45-7500	10.0	WIRE, TRACER YELLOW #14
19-1670	1.0	CONN SPLIT/BOLT COPPER MAX #10 STR