

NOTES:

- 1) ALL WIRE SPLICES TO BE MADE USING A SPLIT BOLT CONNECTOR WRAPPED WITH AQUA-SEAL AND ELECTRICAL TAPE.
- 2) TRACER WIRE FOR PE GAS MAINS TO BE AWG #14 COPPERCLAD STAINLESS STEEL WITH SOLID YELLOW INSULATION.
- 3) TRACER WIRE, STOCK ITEM #45-7500, TO BE INSTALLED PER THE GAS CONSTRUCTION SPECIFICATIONS.
- 4) TEN FEET OF 2" PE 3408 IS INCLUDED. ANY ADDITIONAL PIPE REQUIRED TO BE CALLED FOR BY PLANNER.

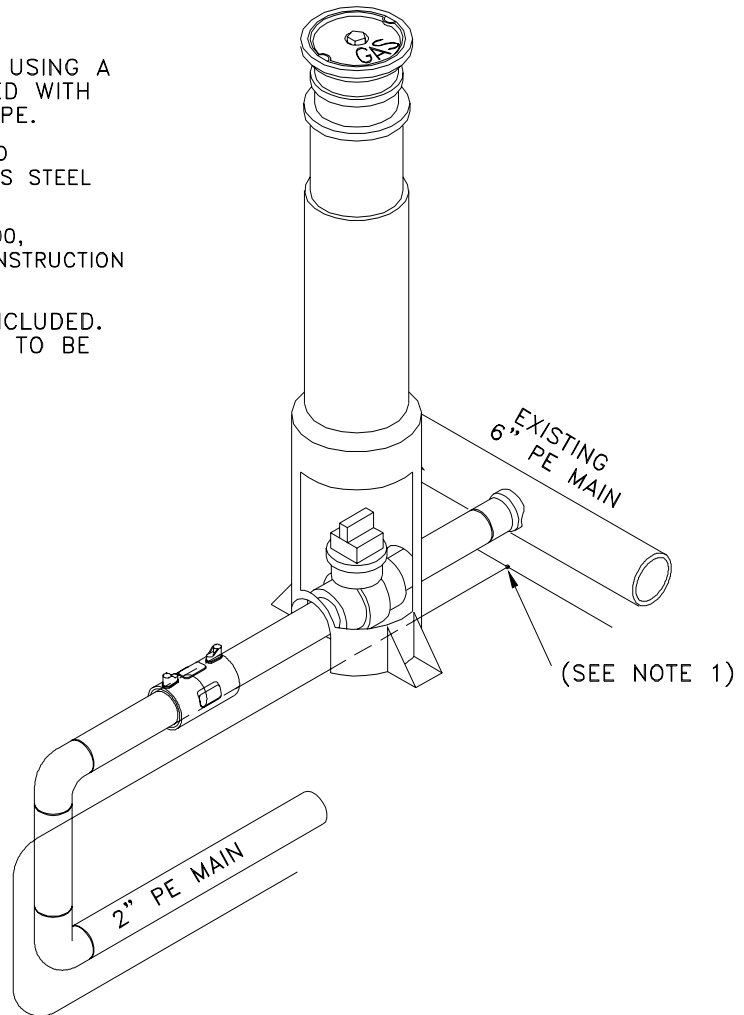

MATERIAL LIST

STOCK #	QTY.	DESCRIPTION
43-2030	1.0	VALVE 2" PE3408
45-5015	1.0	SADDLE BRANCH PLEXCO 6" X 2" PE3408 BUTT FUSION
45-0642	1.0	COUPLING ELECTROFUSION 2" IPS
41-5050	10.0	PIPE PLASTIC 2" IPS PE3408 STRAIGHT JOINTS
45-0913	2.0	ELBOW PE3408 90 DEGREE 2" IPS BUTT FUSION
43-0018	1.0	BOX 1-1/4" AND 2" PE VALVES TRAFFIC RATED H-20
45-7500	10.0	WIRE, TRACER YELLOW #14
19-1670	1.0	CONN SPLIT/BOLT COPPER MAX #10 STR



ENGINEERING & CONSTRUCTION STANDARD

SECTION 5 GAS CONSTRUCTION DRAWINGS
DISTRIBUTION TAP INSTALLATIONS

REVERSE TAP
2" REVERSE TAP OFF 6" PE

SHEET 14 OF 20

DRAWING NUMBER

DTI12G

DRAWN	DESIGN	SUPR	DATE	REV
GD	KS	HB	5/98	7/06