

NOTES:

- 1) LENGTH OF PUP TO BE THREE INCHES. SADDLE PUP TO FIT STEEL MAIN. DO NOT SADDLE VALVE END.
- 2) ALL WIRE CONNECTIONS TO STEEL PIPE TO BE COLDWELDED AND COATED WITH PRIMER, PROTECTO-WRAP AND TAPE. USE COLDWELD STOCK #47-0038. AND COLDWELD SLEEVE STOCK #47-0037.
- 3) STEEL VALVE BOX LID TO BE MARKED BY WELDING "TS" FOR TEST STATION. TEST LEAD WIRE TO BE LONG ENOUGH TO EXTEND ONE FOOT ABOVE GROUND LEVEL AND SHALL TERMINATE IN VALVE BOX.
- 4) USE 3/4" PVC OR PE AS A LEAD WIRE CONDUCTOR PIPE PLACED APPROXIMATELY 6" ABOVE CARRIER PIPE AND INTO TEST STATION BOX.
- 5) ANODE CAN BE INSTALLED VERTICALLY OR HORIZONTALLY BUT MUST HAVE A MINIMAL RADIAL CLEARANCE OF TWO FEET FROM THE STEEL PIPE AND BE POSITIONED AT AN ELEVATION NO HIGHER THAN THE STEEL PIPE.
- 6) TRACER WIRE, STOCK ITEM #45-7500, TO BE INSTALLED PER GAS CONSTRUCTION THE SPECIFICATIONS.
- 7) ALL WIRE SPLICES TO BE MADE USING A SPLIT BOLT CONNECTOR WRAPPED WITH AQUA-SEAL AND ELECTRICAL TAPE
- 8) COAT ALL STEEL PIPE WITH PRIMER, PROTECTO-WRAP AND TAPE. COAT VALVE WITH MASTIC, EXCEPT FOR VALVE STEM.
- 9) TEN FEET OF 2" PE PIPE IS INCLUDED. ANY ADDITIONAL PIPE REQUIRED TO BE CALLED FOR BY PLANNER.

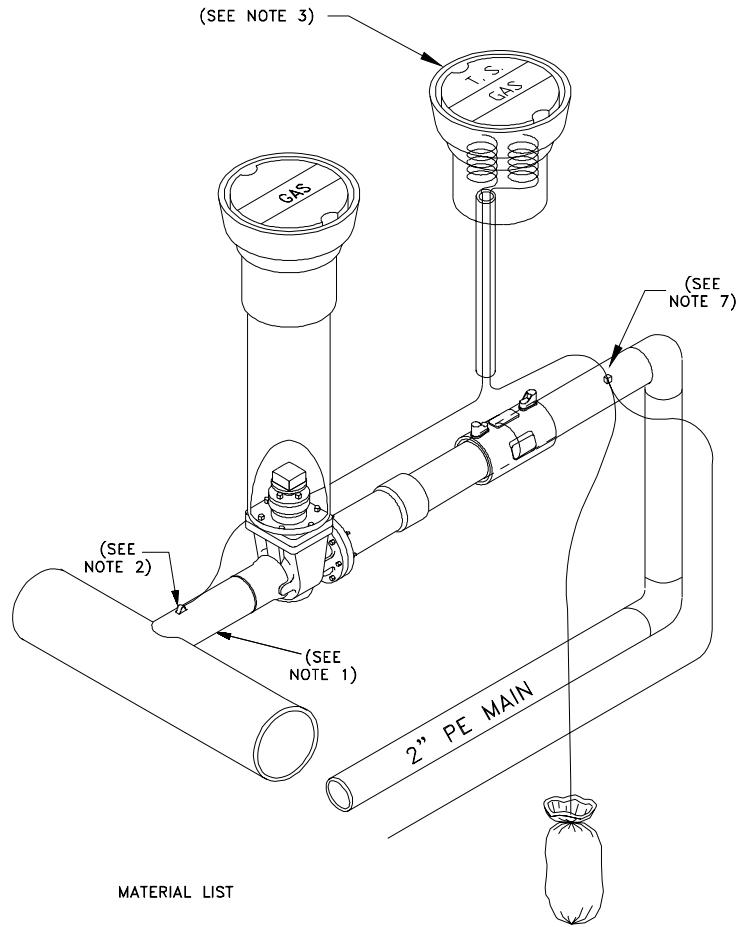

MATERIAL LIST

STOCK #	QTY.	DESCRIPTION
43-0127	1.0	VALVE 2" WELD X FLANGE
45-6030	1.0	TRANSITION FITTING FLANGED 2" IPS PE3408
45-0642	1.0	COUPLING ELECTROFUSION 2" IPS
41-0200	1.0	PIPE 2" STEEL POLYOLEFIN COATED APISL A25
41-5050	10.0	PIPE PLASTIC 2" IPS PE 3408 STRAIGHT JOINTS
45-0913	2.0	ELBOW PE 3408 90 DEGREE 2" IPS BUTT FUSION
47-0040	1.0	GASKET FULL FACE 2 IN.
47-0340	4.0	BOLT MACHINE BLK HEX HEAD W/HEX NUT 5/8" X 2-1/2"
47-0020	1.0	ANODE MAGNESIUM 3 LB. WITH COVERING
45-7500	10.0	WIRE, TRACER YELLOW #14
19-1670	1.0	CONN SPLIT/BOLT COPPER MAX #10 STR
43-0010	2.0	BOX 6" VALVE CAST IRON
43-0095	2.0	COVER BOX VALVE GAS 6"
41-3000	3.0	PIPE PVC 6" SEWER 6.275 O.D. SDR 35 FOR VALVES
47-0180	0.5	PRIMER
47-0260	1.0	TAPE PROTECTO-WRAP 6 IN. X 50 FT.
47-0300	1.0	TAPE BLACK 2 IN. X 100 FT.
47-0182	0.5	MASTIC